

P3PC-E702-03EN

---

---

# fi-4010CU Image Scanner

Operator's Guide

---

---



FUJITSU

## Disclaimers

### ■ FCC declaration

This equipment has been tested and found to comply with the limits for a Class B digital device, pursuant to Part 15 of the FCC Rules. These limits are designed to provide reasonable protection against harmful interference in a residential installation. This equipment generates, uses, and can radiate radio frequency energy and, if not installed and used in accordance with the instruction manual, may cause harmful interference to radio communications. However, there is no guarantee that interference will not occur in a particular installation. If this equipment does cause harmful interference to radio or television reception, which can be determined by turning the equipment off and on, the user is encouraged to try to correct the interference by one or more of the following measures:

- Reorient or relocate the receiving antenna.
- Increase the separation between the equipment and receiver.
- Connect the equipment into an outlet on a circuit different from that to which the receiver is connected.
- Consult the dealer or an experienced radio/TV technician for help.

### FCC warning

Changes or modifications not expressly approved by the party responsible for compliance could void the user's authority to operate the equipment.

### NOTE

- The use of a non-shielded interface cable with the referenced device is prohibited. The length of the parallel interface cable must be 15 meters (50 feet) or less.
- The length of the power cord must be 3 meters (10 feet) or less.

This Class B digital apparatus complies with Canadian ICES-003.

Cet appareil numérique de la classe B est conforme à la norme NMB-003 du Canada.

## ■ Bescheinigung des Herstellers / Importeurs

Hiermit wird bescheinigt, daß *der/die/das*

- fi-4010CU in Übereinstimmung mit den Bestimmungen der
- AmtsbIVfg 243/1991 funktentstört ist. Der Deutschen Bundespost wurde das Inverkehrbringen dieses Gerätes angezeigt und die Berechtigung zur Überprüfung der Serie auf Einhaltung der Bestimmungen eingeräumt.
- Maschinenlärminformationsverordnung 3. GS GV, 18.01.1991:

Der höchste Schalldruckpegel beträgt 70 dB (A) oder weniger gemäß ISO/7779.



As an ENERGYSTAR<sup>®</sup> Partner, Fujitsu Limited has determined that this scanner meets ENERGYSTAR<sup>®</sup> guidelines for energy efficiency. ENERGYSTAR<sup>®</sup> is a U. S. registered mark.

## ■ Use in Enhanced Safety Applications

This Product is designed, developed and manufactured as contemplated for general use, including without limitation, general office use, personal use, household use, and ordinary industrial use, but is not designed, developed and manufactured as contemplated for use accompanying fatal risks or dangers that, unless extremely high safety is secured, could lead directly to death, personal injury, severe physical damage or other loss (hereinafter "High Safety Required Use), including without limitation, nuclear reaction control in nuclear facility, aircraft flight control, air traffic control, mass transport control, medical life support system, missile launch control in weapon system. You shall not use this Product without securing the sufficient safety required for the High Safety Required Use. If you wish to use this Product for High Safety Required Use, please consult with our sales representatives in charge before such use. The manufacturers accept no claims from customers or third parties in relation to, and accepts no responsibility for losses incurred as a result of, the use of this product in enhanced safety applications.

## ■ About the use of mercury

Scanner lamp includes mercury.

To avoid unexpected injury, read the followings carefully.

Doing following actions may result in serious personal injuries:

- Put the substance in the lamp into mouth as it contains mercury.
- Vaporize, crumb, condense the scanner.
- Aspirate the chemical liquid contained in scanner parts.

Dispose of the scanner should be conducted as required by local ordinances or regulations.

### ■ Copying

Copying of paper money, coins, securities and passports issued by government authorities, licenses and permits issued by public authorities and private organizations, official documents, and private documents etc. is illegal and is subject to punishment.

### ■ Copyright

Copyright had items such as books, paintings, prints, maps, drawings, and photographs may be copied only for private or home use, or for similar applications.

Copying for other applications without the consent of the holder of the copyright is illegal.

### ■ Trademarks and Registered Trademarks

Microsoft®, Windows® and Windows® NT are registered trademarks of the Microsoft Corporation in the United States of America and in other countries. ISIS® is the registered trademark of Pixel Translations, a division of Actionpoint Inc.

Adobe and the Adobe logo as well as Acrobat and the Acrobat Logo are trademarks of Adobe Systems Incorporated.

Names of other goods and products occurring in this manual are the registered trademarks or trademarks of the relevant companies.

The contents of this manual may be revised without prior notice.

All Rights Reserved, Copyright © 2001-2002 PFU LIMITED.

No part of this manual may be reproduced in any form without permission.

## Fujitsu Group Offices

Please send your comments on this manual or on Fujitsu products to the following addresses:

### **FUJITSU COMPUTER PRODUCTS OF AMERICA, INC.**

2904 Orchard Parkway, San Jose,  
CA 95134-2009, U.S.A.  
Phone: (1-800)591-5924;  
(1-408)432-6333  
Technical Assistance Center:  
(1-800)626-4686  
Fax: (1-408)894-1709  
Website: <http://www.fcpa.com/>  
E-mail: [info@fcpa.fujitsu.com](mailto:info@fcpa.fujitsu.com)

### **FUJITSU CANADA, INC.**

2800 Matheson Boulevard East,  
Mississauga, Ontario L4W  
4X5, Canada  
Phone: (1-905)602-5454  
Fax: (1-905)602-5457  
Website: <http://www.fujitsu.ca/>  
E-mail: [imaging@fujitsu.ca](mailto:imaging@fujitsu.ca)  
(For Sales Questions)  
[scantech@fujitsu.ca](mailto:scantech@fujitsu.ca)  
(For technical questions)

### **FUJITSU EUROPE LTD.**

Hayes Park Central, Hayes End  
Road, Hayes Middlesex UB4 8FE,  
UK  
Phone: (44-208)573-4444  
Fax: (44-208)573-2643  
Website:  
<http://www.fujitsu-europe.com/>  
E-mail:  
[iwebmaster@fujitsu-europe.com](mailto:iwebmaster@fujitsu-europe.com)

### **FUJITSU DEUTSCHLAND GMBH.**

Frankfurter Ring 211,  
80807 München 40, Germany  
Phone: (49-89)323-78-0  
Fax: (49-89)323-78-100  
Website: <http://de.fujitsu.com/>  
E-mail: [webmaster@fujitsu.de](mailto:webmaster@fujitsu.de)

### **FUJITSU ITALIA S.p.A.**

Via Nazario Sauro, 38  
20099 Sesto San Giovanni (Milan),  
Italy  
Phone: (39-02)26294-1  
Fax: (39-02)26294-201  
Website:  
<http://www.fujitsu-europe.com/>

### **FUJITSU ICL ESPANA, S.A.**

Camino Cerro de los Gamos,  
1 28224, Pozuelo de Alarcon, Madrid,  
Spain  
Phone: (34-91)784-9000  
Fax: (34-91)784-9379  
Website:  
<http://www.fujitsu-europe.com/>  
E-mail: [imagemaster@mail.fujitsu.es](mailto:imagemaster@mail.fujitsu.es)

### **FUJITSU AUSTRALIA LTD**

Fujitsu House 2 Julius Avenue  
North Ryde, N.S.W 2113 Australia  
Phone: (61-2)9776-4555  
Fax: (61-2)9776-4019  
Website: <http://au.fujitsu.com/>

### **FUJITSU TAIWAN LTD.**

19th Fl., No39, Sec.1 Chung-Hwa  
Rd., Taipei, Taiwan R.O.C.  
Phone: (886-2)2311-2255  
Fax: (886-2)2311-2277  
Website: <http://fw.fujitsu.com/>

**FUJITSU SYSTEMS BUSINESS  
(THAILAND) LTD.**

12th Fl., Olympia Thai Tower, 444  
Rachadapisek Road, Samsennok,  
Huay kwang, Bangkok 10320,  
Thailand  
Phone: (662)512-6066  
Fax: (662)512-6068  
Website: <http://th.fujitsu.com/>

**FUJITSU MALAYSIA SDN, BHD.**

7th Fl., Wisma Damansara,  
Jalan Semantan 50490 Kuala  
Lumpur, MALAYSIA  
Phone: (60-3)254-3644  
Fax: (60-3)253-3940  
Website: <http://my.fujitsu.com/>

**FUJITSU PHILIPPINES, INC**

2nd Fl., United Life Building, Pasay  
Road, Legaspi Village Makati,  
Metro Manila, Philippines  
Phone: (63-2)812-4002  
Fax: (63-2)817-7576

**Imaging Products Division,  
PFU LIMITED**

Solid Square East Tower,  
580 Horikawa-cho, Saiwai-ku,  
Kawasaki-shi, Kanagawa  
212-8563, Japan  
Phone: (81-44)540-4658  
Fax: (81-44)540-4639  
Website:  
<http://imagescanner.fujitsu.com/>  
E-mail: [scanners@pfu.fujitsu.com](mailto:scanners@pfu.fujitsu.com)

**FUJITSU ASIA PTE.LTD.**

20 Science Park Road, #03-01,  
Tele Teck Park Singapore Science  
Park II,  
Singapore 117674  
Phone: (65)777-6577  
Fax: (65)771-5499  
Website: <http://sg.fujitsu.com/>  
E-mail: [inquiry@fcsf.fujitsu.com.sg](mailto:inquiry@fcsf.fujitsu.com.sg)

**FUJITSU HONG KONG LTD.**

10/F., Lincoln House, 979 King's  
Road, Taikoo Place, Island East,  
Hong Kong  
Phone: (852)2827-5780  
Fax: (852)2827-4724  
Website: <http://hk.fujitsu.com/>  
E-mail: [scanner@fujitsu.com.hk](mailto:scanner@fujitsu.com.hk)

**FUJITSU KOREA LTD.**

5-11 Fl., Coryo Finance Center  
Building,  
Youido-Dong 23-6, Young  
DungPo-gu,  
Seoul, Korea, 150-010  
Phone: (82-2)3787-6159  
Fax: (82-2)3787-6164  
Website: <http://kr.fujitsu.com/>  
E-mail: [webmaster@fkl.fujitsu.co.kr](mailto:webmaster@fkl.fujitsu.co.kr)

**PFU LIMITED**

**(Corporate headquarters)**  
Nu 98-2 Unoke, Unoke-machi,  
kahoku-gun, Ishikawa 929-1192,  
Japan  
Phone: (81-76)283-1212  
Fax: (81-76)283-4689

## **Note, Liability**

READ ALL OF THIS MANUAL CAREFULLY BEFORE USING THIS PRODUCT. IF NOT USED CORRECTLY, UNEXPECTED INJURY MAY BE CAUSED TO USERS OR BYSTANDERS.

While all efforts have been made to ensure the accuracy of all information in this manual, PFU assumes no liability to any party for any damage caused by errors or omissions or by statements of any kind in this manual, its updates or supplements, whether such errors are omissions or statements resulting from negligence, accidents, or any other cause.

PFU further assumes no liability arising from the application or use of any product or system described herein; nor any liability for incidental or consequential damages arising from the use of this manual.

PFU disclaims all warranties regarding the information contained herein, whether expressed, implied, or statutory.

PFU reserves the right to make changes to any products herein, to improve reliability, function, or design, without further notice and without obligation.

## **Preface**

This manual explains how to use the fi-4010CU image scanner.

This manual contains chapters on the following topics:

COMPONENTS

INSTALLATION AND CONNECTIONS

OPERATING INSTRUCTIONS

MAINTENANCE

TROUBLESHOOTING

INSTALLATION SPECIFICATIONS

It also contains a Glossary of Terms and an Index.



## Conventions

Important information that requires special attention is indicated as follows:



WARNING indicates that serious personal injury may result if you do not follow a procedure correctly.



CAUTION indicates that minor personal injury, loss of data, or damage to the scanner may result if you do not follow a procedure correctly.



A NOTICE provides “how to” tips or suggestions to help you perform a procedure correctly.



A TRIANGLE symbol indicates that special care and attention is required. The drawing inside the triangle shows the specific caution.



A CIRCLE with a diagonal line inside shows action that users are not allowed to do. The drawing inside or under the circle shows the specific action that is not allowed.



Outline characters on a colored background show instructions users should follow. It may include the drawing that shows the specific instruction.

## **Screen Examples In This Manual**

The screen examples in this manual are subject to change without notice in the interest of product improvement.

If the actual displayed screen differs from the screen examples in this manual, operate by following the actual displayed screen referring to the User's Manual of the scanner application you are using.

Furthermore, the screenshots in this manual are for the FUJITSU TWAIN32 scanner driver and the Image Capturing Software Utilities "ScandAll 21" for Microsoft® Windows®.

# Precautions

This section describes precautions to follow when installing the scanner.

To ensure the longevity and proper functioning of your scanner, do not install the scanner in the places and environments described below.

## ■ Warning

Important warnings employed in this manual are as follows.

---

### Do not damage the power cable.



Damage to the power cable may result in fire or electric shock. Do not place heavy objects on, pull, tightly bend, twist, heat, or modify the power cable. Do not use the power cable or socket if it is damaged, or if the plug is loose in the socket.

---

### Use only the specified power cable or extension cable.



Use only the specified power cable or extension cable. Use of other cables may result in electric shock or malfunction.

---

### Use only at the specified voltage. Ensure that too many cables are not connected to the same socket.



Use at other than the specified voltage may result in fire or electric shock. Ensure that too many cables are not connected to the same socket.

---

### Wipe all dust from plug on the power supply cable.



Using a dry cloth, remove all dust on the metal components of the plug, and on all surfaces to which the metal components are attached. Presence of dust may result in fire or electric shock.

---

---

**Do not use the equipment in areas with high levels of oil smoke, steam, humidity, or dust.**



Installation in areas with high levels of oil smoke, steam, humidity, or dust may result in fire or electric shock.

---

**Do not use the equipment if an abnormal smell or noise is apparent.**



If the equipment overheats, emits smoke or abnormal smells, or makes abnormal noises, switch power OFF immediately and remove the power plug from the socket. Check that smoke is no longer emitted, and call your dealer or maintenance service center. Do not attempt to repair the equipment yourself under any circumstances.

---

**Ensure that water or foreign matter does not enter the equipment.**



Do not insert or drop metal objects or combustible objects into openings (e.g. ventilation openings).



Ensure that liquids (e.g. coffee) and metal objects (e.g. paper clips) do not enter the equipment.



Do not spill or leak water onto the equipment.



If foreign matter (e.g. water, other liquids, metal objects) enters the equipment, switch power OFF immediately and remove the power plug from the socket, and call your dealer or maintenance service center. Particular care is required if children are in the vicinity.



---

**Do not open the equipment without good reason.**



The equipment contains high-voltage components, and should not be dismantled or modified.

---

**Always remove the plug from the socket before fitting or removing optional equipment.**

**Electric shock**



Switch the equipment power supply OFF, and remove the plug from the socket, before fitting or removing optional equipment in accordance with the specified procedure.

**Do not**



Grip the plug to remove the power cable from the socket.

---

**Switch power OFF if the equipment is damaged.**



If the equipment is dropped, or covers etc. have been damaged, switch power supply OFF, remove the plug from the socket, and call your dealer or maintenance service center.

---

**Do not place in wet areas.**

**Electric shock**



Do not place the scanner where liquid spills may occur.

---

## ■ Caution

Important cautions employed in this manual are as follows.

---

**Do not touch the power cable with wet hands.**

**Electric shock**



Do not remove or insert the plug with wet hands. Wet hands may result in electric shock.

---

**Do not look at the light source directly.**

**Do not**



Do not look at the light source of the equipment directly as this May result in injury.

---

**Always ensure that the equipment is installed in a stable location.**



Ensure that no part of the scanner is liable to fall from the desk, and that the base of the equipment is level.



Ensure that the equipment is installed in a stable location. The equipment should be installed in a location that is level and subject to minimal vibration.

---

**Insert the power plug fully into the socket.**



Ensure that the power plug is inserted as far as possible into the socket.

---

**Do not block the ventilation openings.**



If the ventilation openings are blocked the interior of the equipment will overheat, and may result in fire or malfunction.

---

**Do not place heavy objects on, and do not stand on, the equipment.**



Placing heavy objects on the equipment, or standing on the equipment while working, may result in injury.

---

**Remove the power plug from the socket before moving the equipment.**



Moving the equipment with the cable connected may result in damage to the cable, fire or electric shock, or injury. Always remove the power plug from the socket, and disconnect extension cables, before moving the equipment.

Always clear the floor before beginning work.

---

**Avoid static electricity.**



Ensure that the equipment is installed away from strong magnetic fields, sources of electrical noise and airflow.

If the scanner is used near an air conditioner, copying machine, or TV set, the scanner may operate incorrectly.

Avoid static electricity. Static electricity may be a cause of mis-operation of the equipment. Ensure that the floor and desk on which the equipment is installed is of a material that does not generate static electricity.

---

**Ensure that clothing, ties, and hair do not become caught in gears and rollers.**



Clothing, ties, and hair becoming caught in moving components such as gears and rollers may result in injury.

---

**Remove the power plug from the socket if the equipment is to be out of use for a considerable length of time.**



For safety reasons, the power plug should be removed from the socket if the equipment is to be out of use for a significant time.

---

**Remove the power cable from the socket immediately thunder is heard.**



Remove the power cable from the socket if thunder is heard nearby. The equipment may be damaged if it remains connected during an electrical storm.

---

**Do not leave the equipment in direct sunlight.**



Leaving the equipment in direct sunlight or in the vicinity of air conditioning equipment will result in the internal temperature of the equipment increasing, and may result in fire or malfunction.

Ensure that the equipment is installed in a well ventilated area.

---

**Do not use aerosol spray near the scanner.**



Do not use aerosol sprays, for example, to clean the scanner. Air sprayed from aerosol sprays cause dirt and dust to enter the scanner, resulting scanner failure and malfunction.

April, 2002    Rev.03
-----------------------

# CONTENTS

<b>Chapter 1. COMPONENTS</b>	<b>1</b>
1.1 Overview	1
1.1.1 Features of fi-4010CU image scanner	1
1.2 Checking the Components	2
<b>Chapter 2. INSTALLATION AND CONNECTIONS</b>	<b>5</b>
2.1 Unlock the Shipping lock	5
2.2 Installation of the ADF paper chute A, ADF paper chute B and Document stopper	6
2.3 Connecting the interface cables	7
2.3.1 Connecting USB cable	7
2.3.2 Connecting ADF cable	7
2.3.3 Connecting Power cable	7
2.3.4 Installation of scanner driver and software	8
<b>Chapter 3. OPERATING INSTRUCTIONS</b>	<b>9</b>
3.1 Loading Documents on the Flatbed	9
3.1.1 Check the document condition	9
3.1.2 Reading a Page from a Thick Book	10
3.2 Scanning document with ADF	11
3.2.1 Confirming document condition	11
3.2.2 Setting documents	13
3.3 Scanning documents	15
<b>Chapter 4. MAINTENANCE</b>	<b>16</b>
4.1 How to solve paper jams	16
4.2 Daily maintenance	17
4.3 Cleaning	17



4.3.1 Cleaning materials _____	17
4.3.2 Cleaning the Flatbed unit _____	18
4.3.3 Cleaning the ADF unit _____	19
<b>4.4 Consumables _____</b>	<b>22</b>
4.4.1 Part number and Replacement cycle _____	22
4.4.2 Replacing Pad ASY _____	23
<b>Chapter 5. TROUBLESHOOTING _____</b>	<b>26</b>
<b>A. Installation Specifications _____</b>	<b>28</b>
Dimensions _____	28
<b>GLOSSARY OF TERMS _____</b>	<b>29</b>
<b>INDEX _____</b>	<b>32</b>
<b>Declaration of Conformity _____</b>	<b>34</b>

# Chapter 1. COMPONENTS

This section describes checking the components, Units, and Assemblies of the scanner, and operator panel arrangement, and the function of parts.

## 1.1 Overview

This section describes overview and features of fi-4010CU.

### 1.1.1 Features of fi-4010CU image scanner

fi-4010CU image scanner (this equipment) can scan high-quality image.

The scanner can perform the following functions when used in conjunction with software applications.

- Save images in several formats such as TIFF and Bitmap
- Output data to a printer when connected to a personal computer.

Features

- High quality ADF (Automatic document feeder)  
It meets business purpose
- Compact and lightweight  
Easy to install
- Color scanning at 600x600dpi

## 1.2 Checking the Components

These high precision components must be handled carefully.  
Confirm that all the components shown in the following figure have been received.  
If any component is missing, please contact your sales agent.

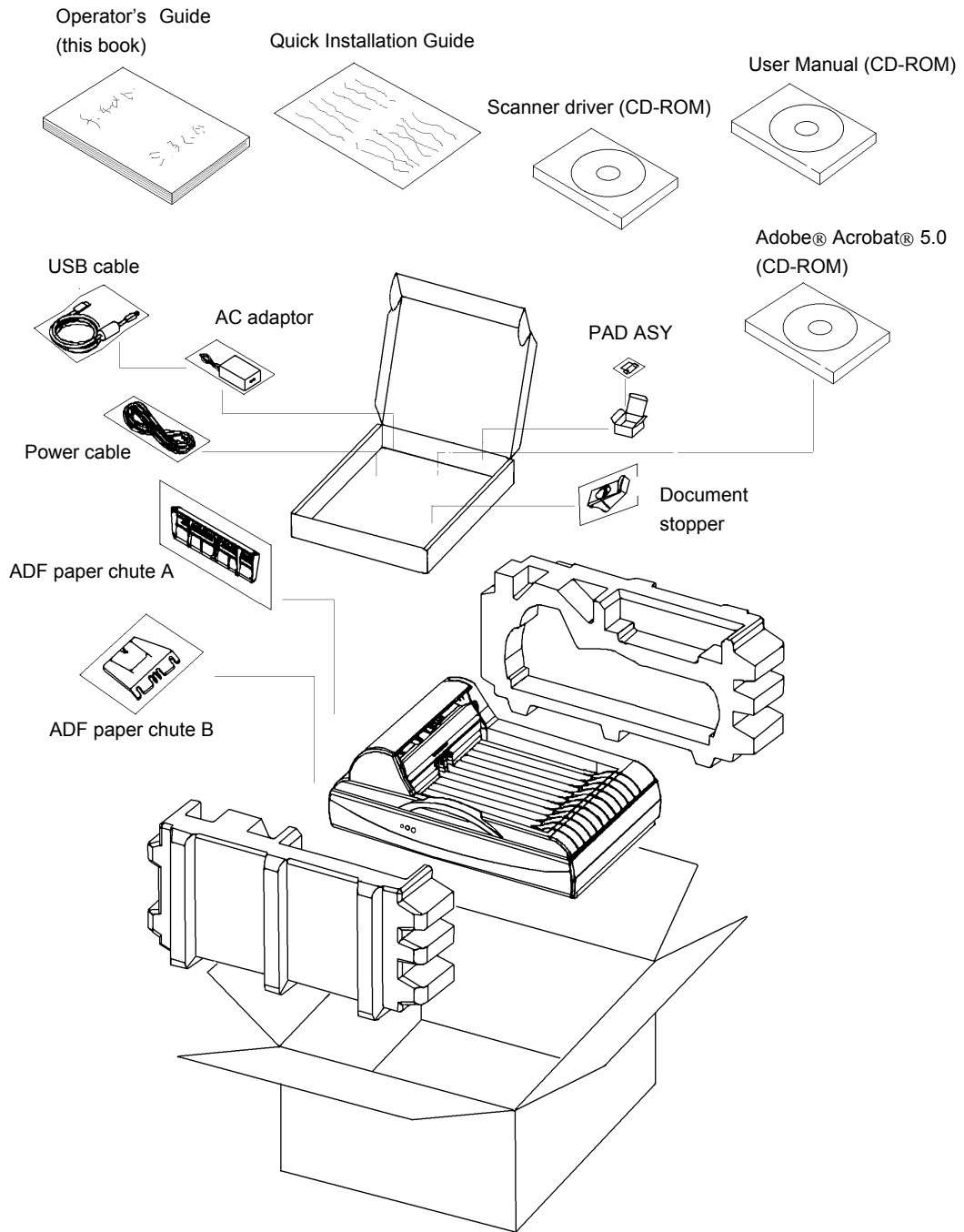

### 1.3 Units and Assemblies

This section shows the exterior view and assemblies of the scanner.

This section also provides the name of each part and describes its functions.

#### ■ Units

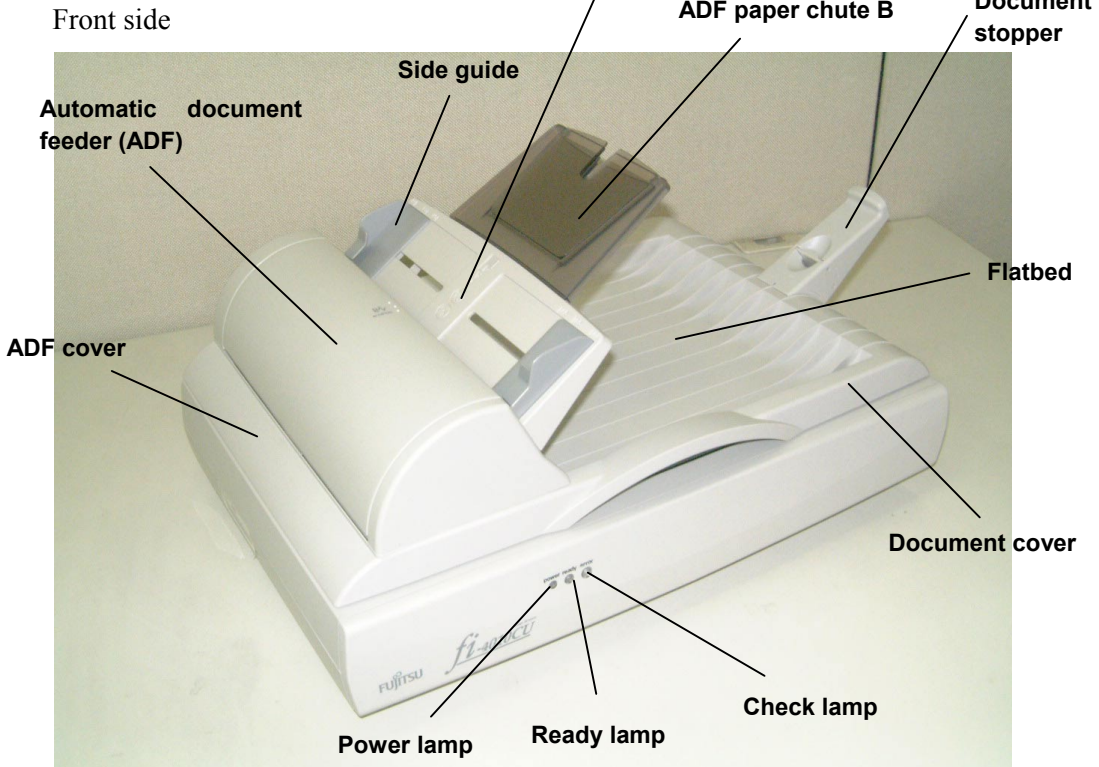

Part	Function
ADF paper chute A and ADF paper chute B	Holds the documents to be fed by the automatic document feeder (ADF).
Side guide	Holds the documents straight.
Document stopper	Needs to be adjusted dependent upon paper size being fed into the ADF.
Document cover	ADF: Stacks the read documents. Flatbed: Closes over and keeps in place the document to be read.
Automatic document feeder (ADF)	Automatically feeds documents to the reading position.

ADF cover	Open when paper jam occurs to remove the document paper.
Flatbed	It is used when reading one page at a time.
Power lamp	It is turned on when the power is turned on.
Ready lamp	It is turned on when the reading movement of the documents is possible.
Check lamp	When an error occurs, it is turned on.

Backside

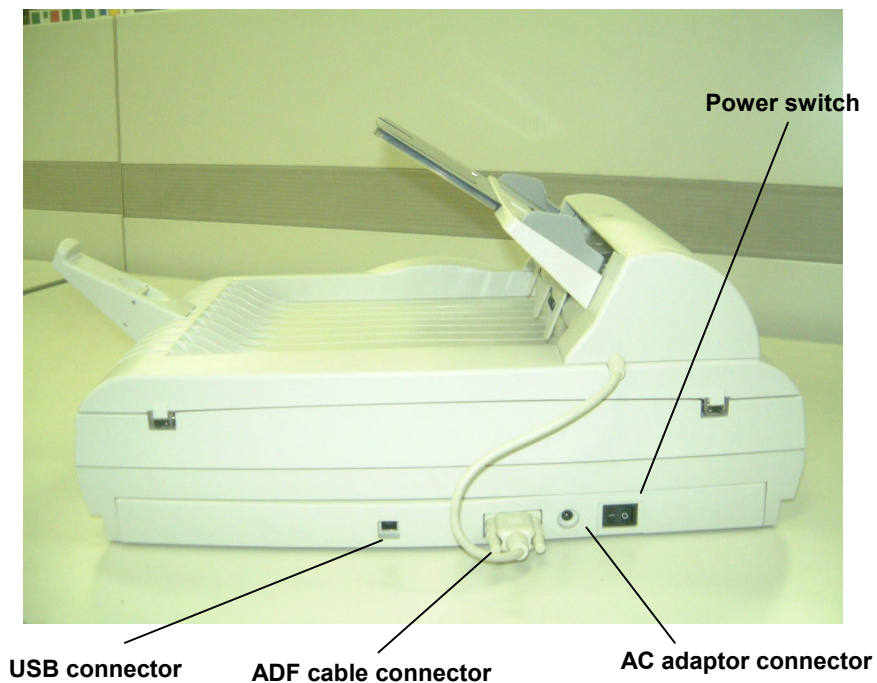

<b>Part</b>	<b>Function</b>
Power switch	Turns the power On or Off.
AC adaptor connector	Connects to an AC adaptor.
ADF cable connector	Connects to an ADF cable.
USB connector	Connects to a PC with USB cable.

## Chapter 2. INSTALLATION AND CONNECTIONS

This section describes how to connect the scanner to the PC.

Please follow the procedure below.

See chapter A. “Installation Specifications” for device appearance.

### 2.1 Unlock the Shipping lock

To keep the scanner from being damaged during shipping, the carrier unit is fixed with a Shipping lock.

After placing the scanner where it will be installed, release the Shipping lock as explained below.

1. Turn the Shipping lock to “unlock”.

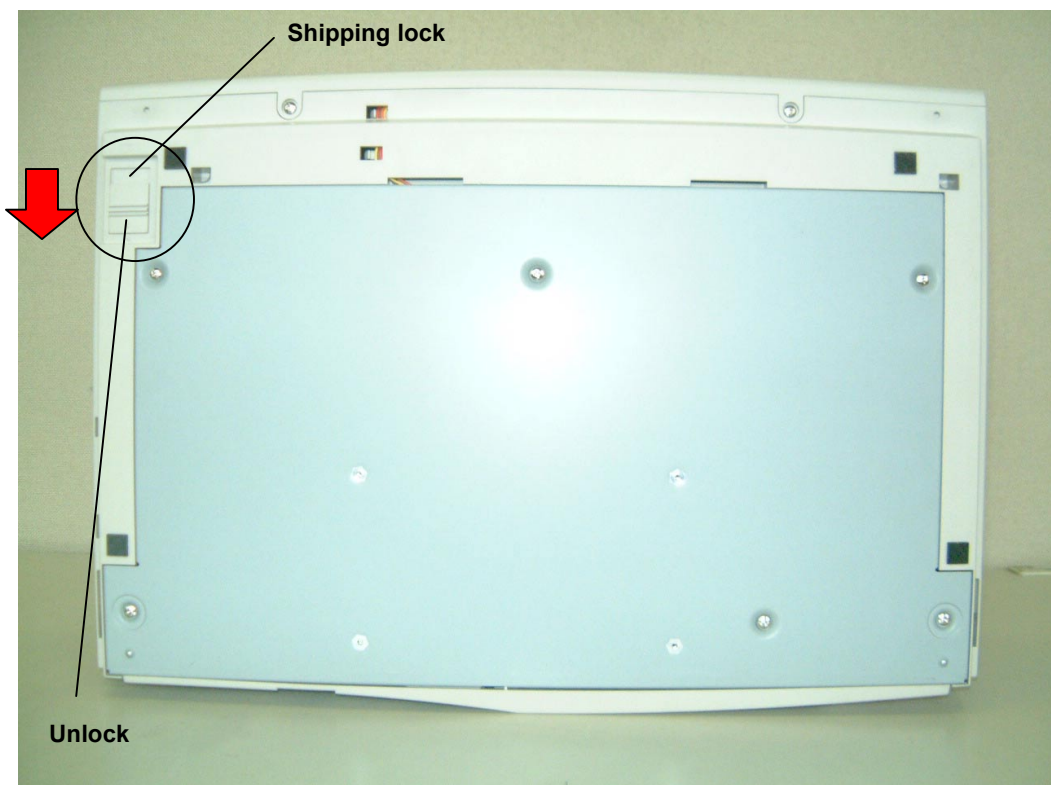

## 2.2 Installation of the ADF paper chute A, ADF paper chute B and Document stopper

Place ADF paper chute A, ADF paper chute B and Document stopper.

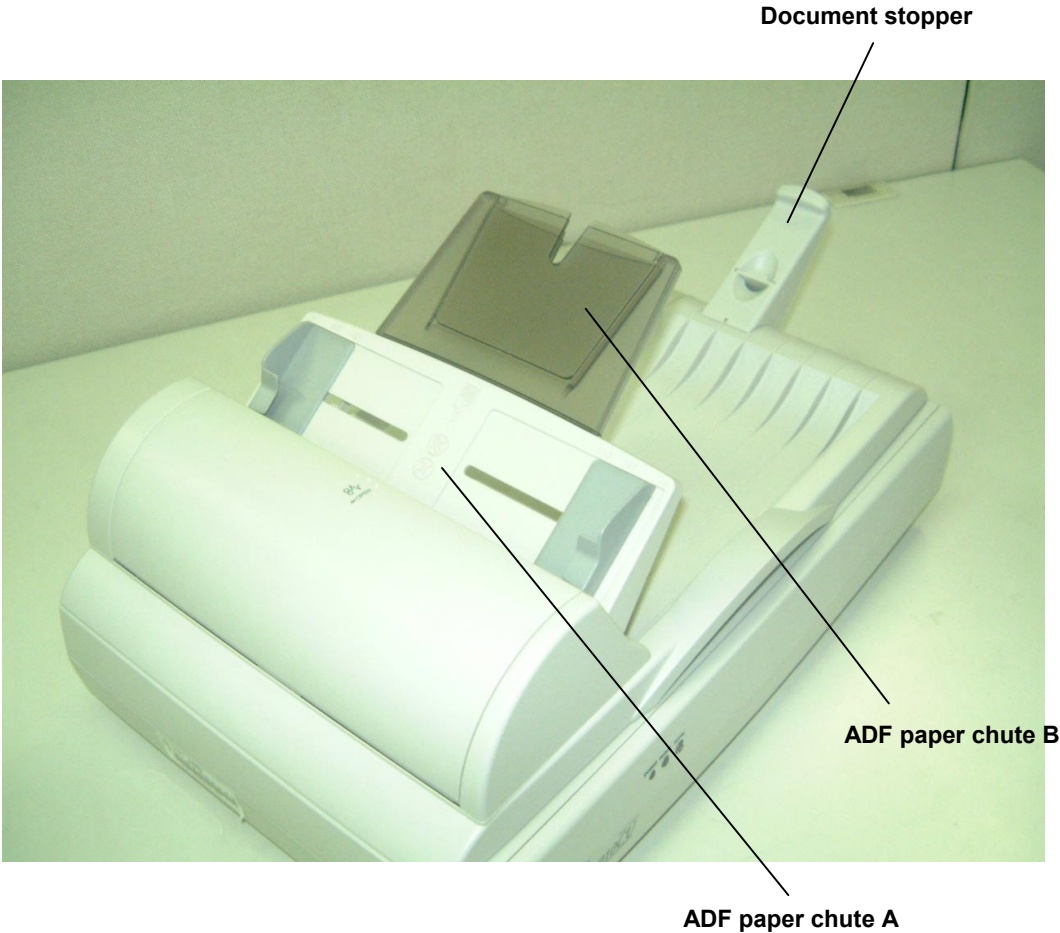

## **2.3 Connecting the interface cables**

This section describes how to connect Power cable, USB cable and ADF cable, and how to install scanner driver.

### **2.3.1 Connecting USB cable**

Plug the USB cable into the USB connector.

Connect the opposite side of the connector to the PC.

#### **NOTE**

- Be sure to use the USB cable, which comes as an accessory with this scanner. We do not confirm the correct operation of a commercial USB cable.
- When connecting to a USB hub, use the first stage USB hub that is closest to the computer. If you use the second or later, the scanner may not operate correctly.

### **2.3.2 Connecting ADF cable**

Plug the ADF cable into the ADF cable connector and secure with the two fasteners.

### **2.3.3 Connecting Power cable**

- 1) Connect the Power cable to the AC adaptor connector of the scanner.
- 2) Plug the AC adaptor into outlet.



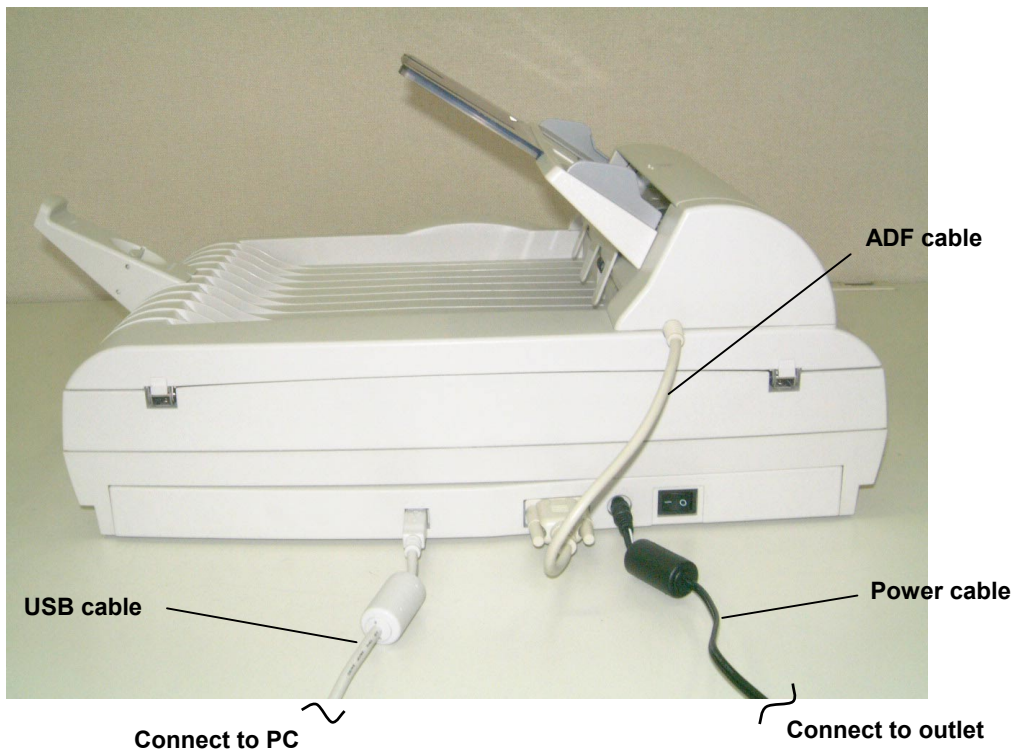

### **2.3.4 Installation of scanner driver and software**

Install the scanner driver and software from the scanner driver CD-ROM included with the scanner.

Installation method is described in the attached Quick Installation Guide.

## Chapter 3. OPERATING INSTRUCTIONS

Place the documents into the ADF paper chute and scan using the ADF.  
This section describes how to scan the document.

### NOTE

Refer to “4.3.3” for periodic cleaning.

### 3.1 Loading Documents on the Flatbed

Place the document face down and align the top left corner with the reference mark.

#### 3.1.1 Check the document condition

Follow the instruction below when the document is smaller than the Document bed.

### CAUTION

Do not look directly at the light source during the read operation.

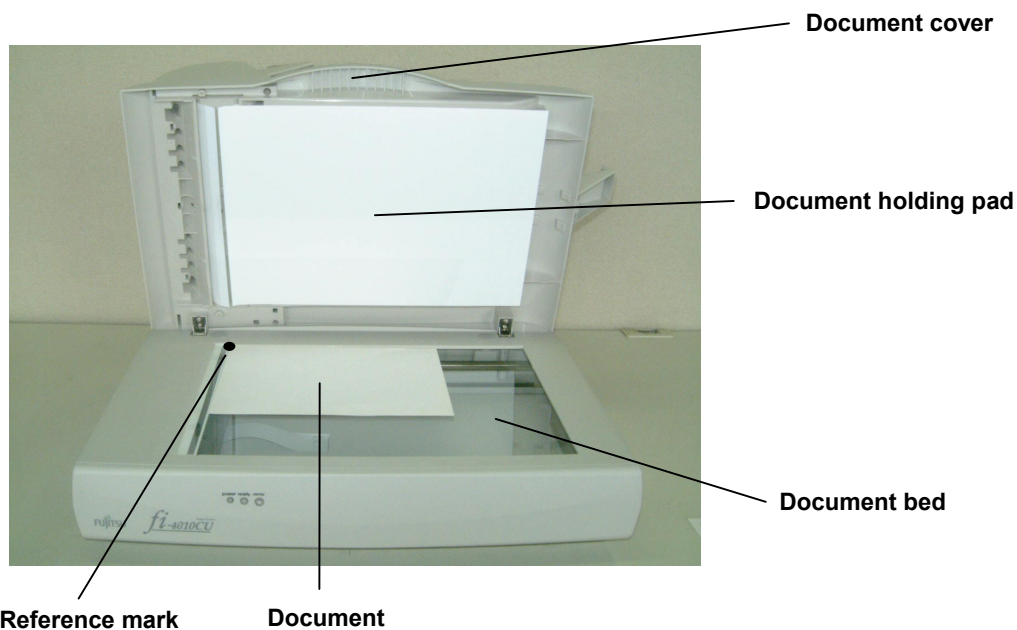

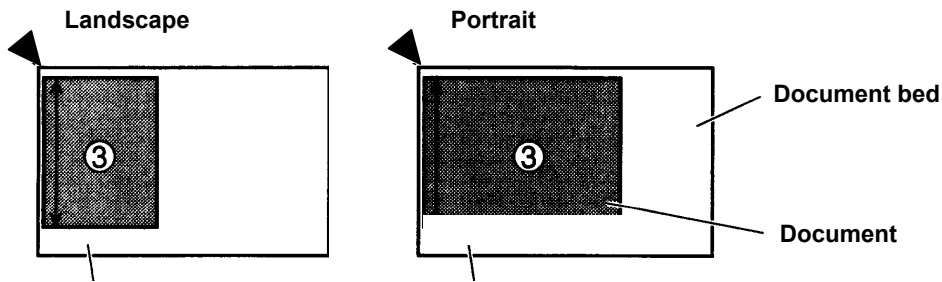

Place the document align the top left corner.

- 1) Open the document cover.
- 2) Place the document face down and align the top left corner with the reference mark. Extend the folded document before scanning.
- 3) Slowly close the document cover.
- 4) Issue the read command from the host system.

### 3.1.2 Reading a Page from a Thick Book

Thick documents such as books should be scanned as follows.

- 1) Open the document cover to an angle of approximately 90 degrees, and lift up the cover (in the direction of the arrow) to remove it.
- 2) Please note that the not seated part of the document is not scanned correctly.
- 3) Do not move the document during the read operation.

#### NOTE

Do not remove Document cover for any other purpose.

## 3.2 Scanning document with ADF

This section explains the operation required before scanning a document.

If you operate the equipment by a method other than described in this section, a paper jam or reading error may occur.

### 3.2.1 Confirming document condition

This section explains documents that can be read and those that are difficult to read.

#### Readable documents

Document type	- Wood free paper - Wood containing paper - Paper for indirect electrostatic process
Ream weight	52 to 127 g/m <sup>2</sup> (13.9 to 34 lb)
Size	A4, A5, B5, letter size, legal size

The documents may be difficult to read.

A preliminary document feed may be necessary to avoid unexpected errors.

If documents slip or jam in the ADF (JAM error) or double feeds occur frequently, scan the documents manually using the Document bed.

The following documents may be difficult to scan properly using the ADF.

- Paper with clips or staples
- Paper written on with ink
- Paper of uneven thickness (for example, envelopes)
- Excessively creased or curled paper
- Paper with large rumples or curls
- Paper with folds or tears
- Tracing paper
- Coated paper
- Carbon paper, pressure sensitive paper, carbonless paper

- Paper larger than letter size in width (216 mm) and legal size in Length (356 mm)
- Materials other than paper (for example, cloth, metal foil, or OHP film)
- Light sensitive paper
- Paper perforated peripherally
- Nonrectangular paper
- Paper lighter than 52 g/m<sup>2</sup> (13.9 lb) or heavier than 127 g/m<sup>2</sup> (34 lb)
- Paper of uneven width
- Very thin paper

 **NOTE**

Avoid scanning documents coated with pencil lead as this will make the roller dirty.  
Clean roller frequently when scanning many documents.

 **NOTE**

Carbonless paper contains chemicals which may damage pad or rollers used for document feeding (for instance, Pick roller), therefore note to the following.

Cleaning: In the event that mis-picks occur frequently when scanning carbonless paper, clean Pad and Pick roller by referring to section 4.3.3.

Parts replacement: The life of the Pick roller and Feed roller may be shortened when scanning carbonless paper as compared to paper produced by wood.

### 3.2.2 Setting documents

This section explains how to set documents.

#### Loosening documents

Before setting documents, sufficiently loosen them by the following procedure:

- Grasp no more than 25 sheets in a stack.
- Hold the ends of stack with both hands, and bend the documents.
- Hold the documents strongly with both hands so that both ends of the documents are slanted, and then unbend the documents so that they are inflated.
- Repeat the process described above two or three times.
- Turn the stack by 90° and loosen it in the same manner as above.

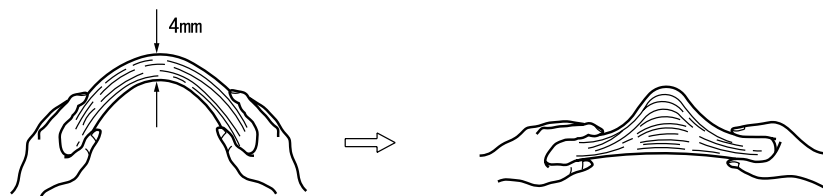

#### NOTE

The documents to be set should be less than 25 sheets.  
Setting more than 25 documents may cause a paper jam or reading problem.

Make sure no documents are set on the flatbed.

When scanning with the ADF, make sure that no documents are placed on the flatbed. Any documents on the flatbed will raise the flatbed cover and cause image quality to be degraded.

#### NOTE

Set the side to be scanned facing up.

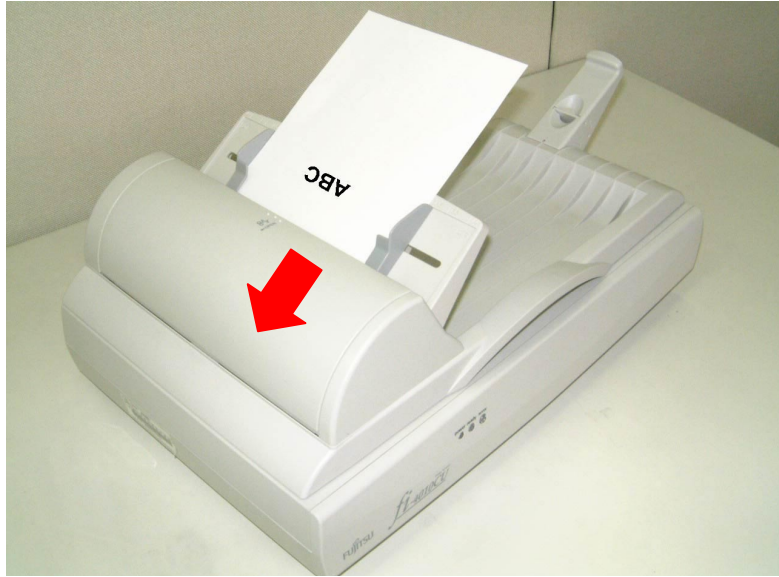

Reading direction

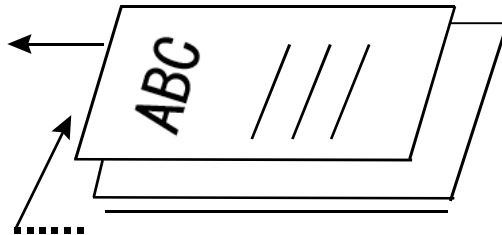

Standard side

### 3.3 Scanning documents

This section explains how to scan documents.

- 1) Make sure that the power to the personal computer and the scanner is ON.
- 2) Check the document condition.

For details, see Section 3.2.1, "Confirming Document Condition."

- 3) Before setting documents, sufficiently loosen them.

For details, see Section 3.2.2, "Setting Documents."

- 4) Set the documents on the ADF paper chute.

- The maximum number of papers placed into the ADF is 25.
- Prepare the documents for feeding.

For details, see Section 3.2.2, "Setting Documents."

- Place the side to be scanned facing up.
- Insert the documents into the automatic document feeder until they softly touch the back of the automatic document feeder. Forcing documents excessively into the ADF may result in multiple papers feeding simultaneously. Also, make sure that the ends of the pages are not folded down.

- 5) Adjust the document guides to the document width. Straighten the documents and set them into the ADF. If the documents are placed loosely between the left and right guides, they may be read diagonally.

- 6) Start scanning from the PC.

- 7) After scanning completes, take the documents out from the stacker.



## Chapter 4. MAINTENANCE

This chapter explains how to resolve paper jams, perform daily maintenance and cleaning.

### NOTE

Clean the ADF unit as described in section 4.3.3.

### 4.1 How to solve paper jams

#### CAUTION

Inside ADF may become extremely hot.

When a paper jam occurs while scanning using the ADF, follow the procedure below to remove the paper.

1. Remove papers from the ADF paper chute.
2. Open the ADF cover.



3. Remove the jammed paper.
4. Close the ADF cover completely.

 **NOTE**

Make sure to close the ADF cover completely. Otherwise, paper jam or reading error may occur.

## 4.2 Daily maintenance

To keep scanner performance stable, keep the following notes in mind during maintenance.

Follow the procedure in section 4.3 below to clean the scanner surface, the Flatbed, and the ADF unit. Cleaning the ADF unit is especially essential.

## 4.3 Cleaning

This section describes how to clean the scanner.



**WARNING**



When cleaning the scanner, turn off the power, and unplug the AC cable from the outlet.

### 4.3.1 Cleaning materials

The table below shows the cleaning materials that re used on this scanner.

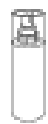
Cleaning Materials	Remarks
Cleaner F1 (or isopropyl alcohol)  	1 bottle  Moisten cloth with this fluid and wipe the scanner clean.
Soft, dry cloth	

For details on Cleaner F1, consult the agent where you bought your scanner.

#### 4.3.2 Cleaning the Flatbed unit

##### NOTE

- Detergent for cleaning windows or glass cleaner can be used instead of cleaning fluid. However, do not use paint thinner or other organic solvents.
- Do not allow moisture to get inside the device during cleaning.

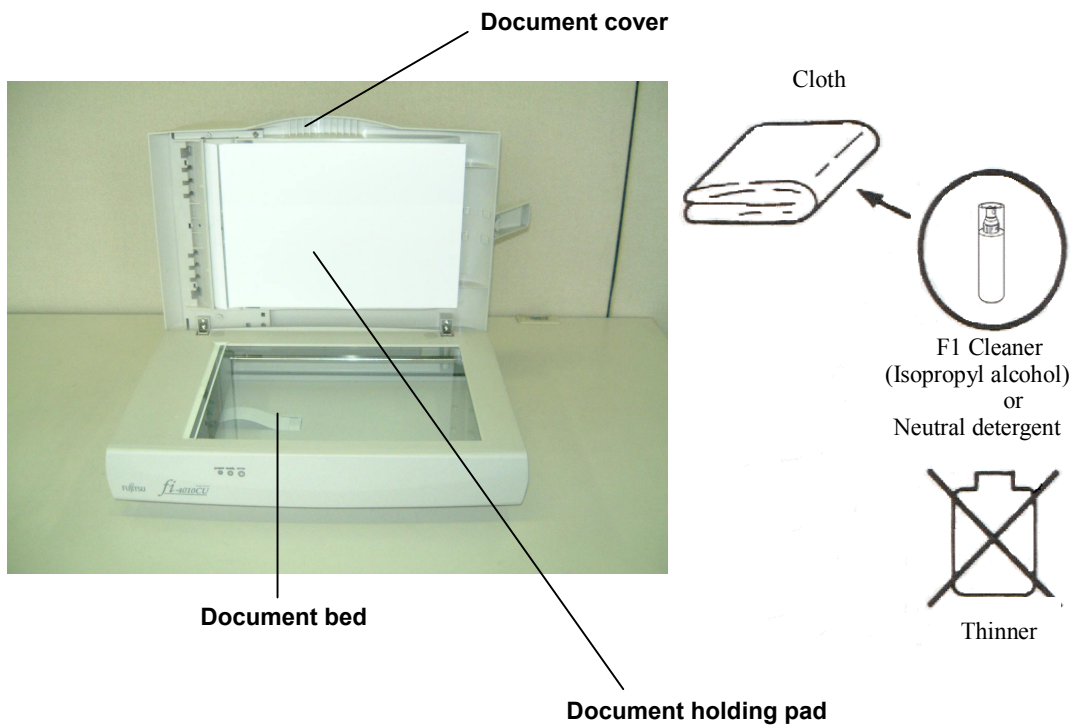

Follow the procedure below to clean Flatbed.

1. Open the document cover.
2. Clean the following locations using a soft, dry cloth moistened with cleaning fluid.

### **Document holding pad**

Wipe gently.

### **Document bed**

Wipe lightly.

3. Wait for cleaned parts to dry.
4. Gently close the document cover.

#### **4.3.3 Cleaning the ADF unit**



#### **CAUTION**

When the scanner is in use, the surface of the glass inside the ADF becomes hot.  
Before cleaning ADF, disconnect the AC adapter from the power outlet, and wait at least 15 minutes for the glass to cool down.

Clean the ADF unit every 1000 scans. This figure may differ depending upon the type of paper being scanned. For instance, scanning pages that contain excessive or insufficiently fused toner may require the scanner to be cleaned more frequently.

Follow the procedure below to clean ADF.

1. Open the ADF by tilting its cover to the left.
2. Clean the following locations with a soft, dry cloth moistened in isopropyl alcohol.

#### **Pad ASY**

Clean the Pad ASY (rubber surface) in the direction of arrow. When doing this, take care not to damage the pick springs, Mylar sheet and sensor lever.

#### **Pick roller**

Lightly clean the Pick rollers taking care not to scratch the roller surfaces. Take particular care when cleaning these rollers, as black foreign matter on these rollers affects document pick performance.

## Plastic roller

Clean Plastic roller softly not to damage its surface. Try to remove any black stain witch may degrade the performance of paper feeding,

## ADF paper chute

Clean ADF paper chute A and B softly.

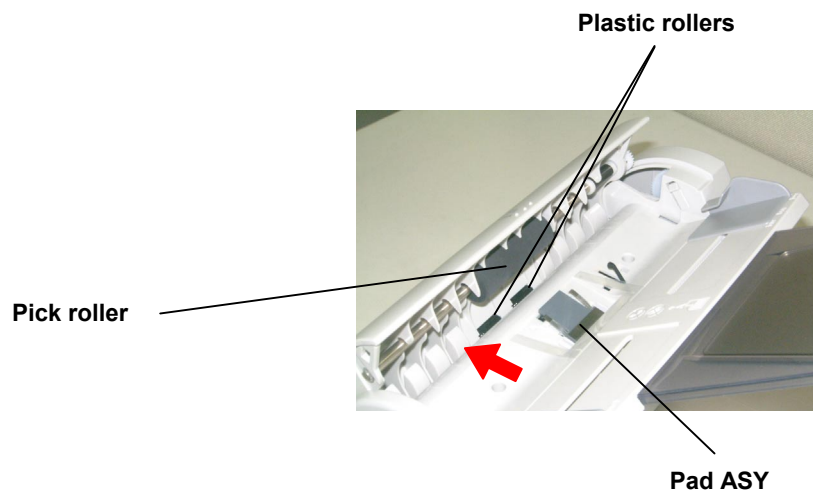
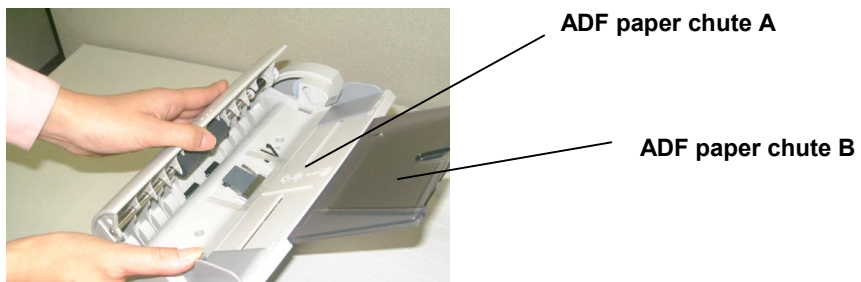

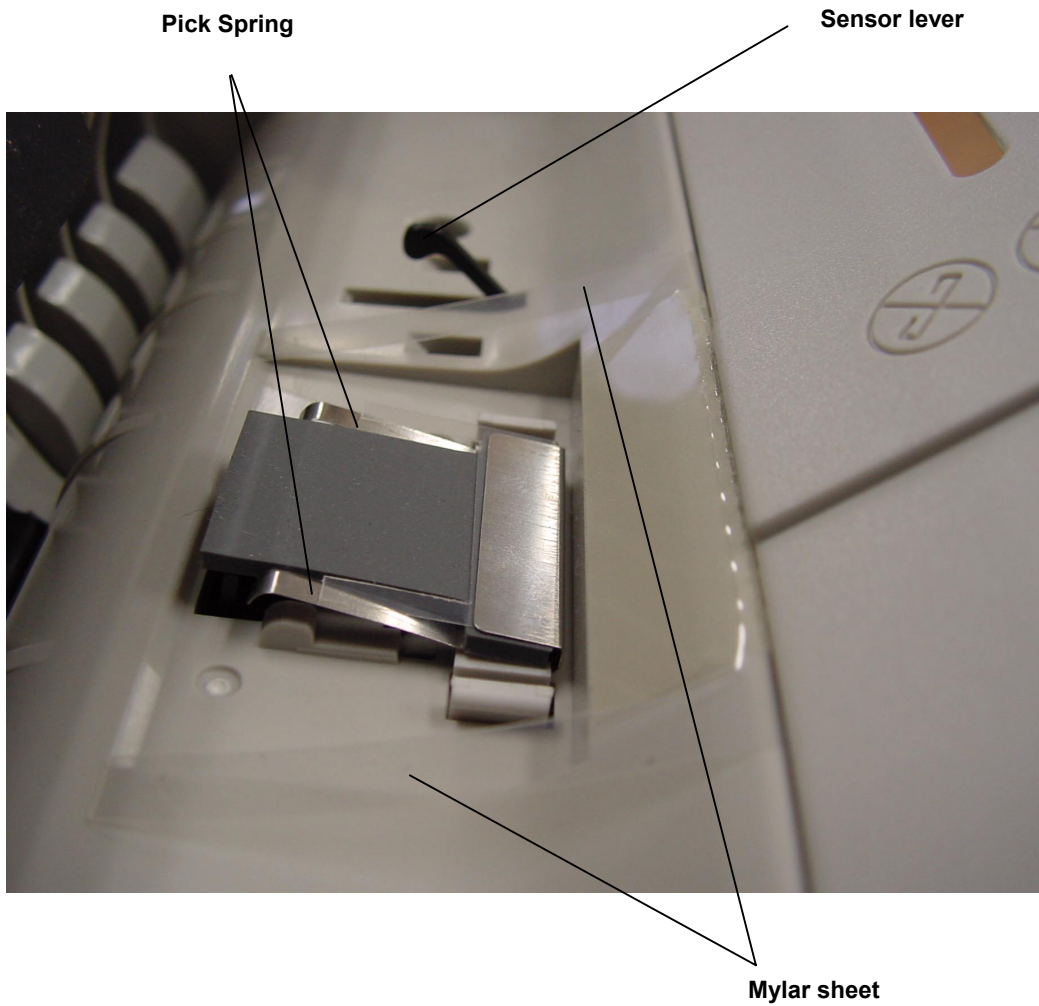

3. Close the ADF.

 **NOTE**

Make sure that the ADF is closed completely after cleaning. Otherwise, a paper jam or reading error may occur.

## 4.4 Consumables



### CAUTION

Turn off the power and disconnect the AC adapter power plug from the outlet before cleaning the scanner.

### 4.4.1 Part number and Replacement cycle

The following table lists consumables used in the scanner.

Be sure to keep some consumables in stock.

The customer is responsible for changing these items periodically.

If they are not changed as recommended, the scanner may not function properly.

No.	Name	Part number	Replacement cycle
1	Pad ASY	CA06009-G009	Up to 20000 sheets, or 1 year

Replacement cycle may differ depending on the type of paper being scanned. The figure above is estimated under the following paper condition:

A4 size, 64g/ m<sup>2</sup> (20 lb), wood free paper.

### NOTE

Use only the specified consumables. Do not use other consumables.

#### 4.4.2 Replacing Pad ASY



#### CAUTION

Inside ADF may become extremely hot. Avoid injury.

To remove Pad ASY:

1. Open ADF cover.
2. Push both sides of the clamp so that Pad ASY can be lifted up for removal.

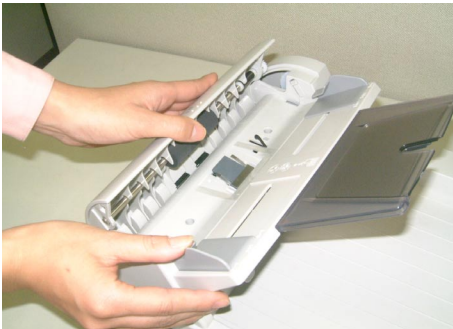

Pad ASY

To mount Pad ASY:

3. Prepare a new Pad ASY.
4. Hold both sides of the clamp and mount Pad ASY into pad holder.

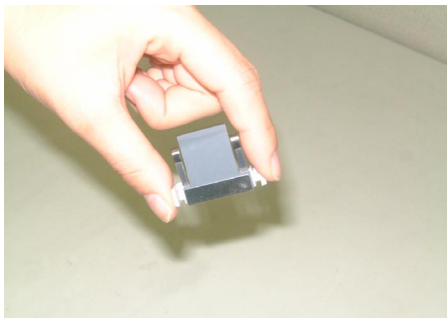

#### NOTE

Make sure that the Pad ASY is installed correctly.  
Incorrect installation may cause a paper jam and reading error.



5. Press down on the center of the ADF.
6. Reset the pad counter.

The following shows the procedure for resetting the pad counter.

- (1) When turning on the power, check that the scanner and the personal computer are connected.
- (2) Double click the " Scanners and Cameras " icon on the operator panel of the host computer.

The [Scanners and Cameras] screen is displayed.

- (3) Double click the "fi-4010CU".
- (4) Click the "Device Set" tab. The following panel appears.

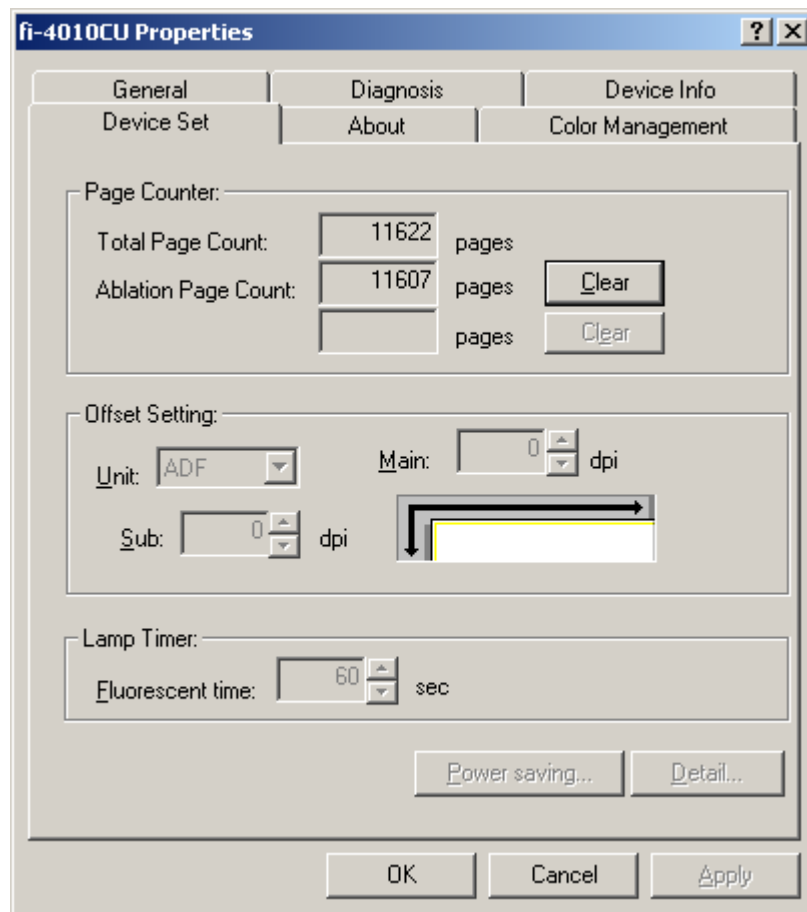

After clicking the [Clear] button beside the "Ablation Page Count" in "Page Counter", click the [OK] button.

This returns the pad counter to "0".

 **NOTE**

This chapter explains samples of the screens in Windows® 2000. The screens and operations may differ slightly if the OS that you are using is other than Windows® 2000.

Also, when FUJITSU TWAIN32 scanner driver is updated the screens and operations noted in this chapter will differ slightly.

## Chapter 5. TROUBLESHOOTING

If a problem occurs, check the following items before contacting the manufacturer's authorized service center.

Symptoms	Check point	Action to recover
The power is not turned on.	Is the AC adapter connected correctly?	Connect the AC adapter correctly.
	----	Disconnect AC adapter and turn off the scanner. Connect power cable and power the scanner turned on again. If the power still does not turned on, contact the manufacturer's authorized service center or the distributor from which you purchased your scanner.
Read operation is not started.	Are the documents loaded correctly on the ADF paper chute?	Load the documents in the ADF properly.
	Is the ADF completely closed?	Completely close the ADF.
	Is the interface cable connected correctly?	Connect the interface cable correctly.
Picture and photograph image quality is not good.	Is halftone processing selected?	Select the halftone mode from the driver screen.
	Are the Flatbed and ADF dirty?	Follow the procedure described in section 4.3 to clean.
Character and line quality is not good.	Is halftone processing selected?	Select "Binary" mode at the driver screen.
	Are the Flatbed and ADF dirty?	Follow the procedure described in section 4.3 to clean.
Images are distorted or misaligned.	Are the documents loaded straight between the ADF paper chute?	Set the documents straight by using document guide.
Double feed occurs frequently	Is Pad ASY dirty?	Follow the procedure described in section 4.3.3 to clean Pad ASY
	Is Pad ASY worn out?	Replace Pad ASY

Symptoms	Check point	Action to recover
Papers were not fed completely. (scanner stopped feeding)	Is Pick roller dirty?	Follow the procedure described in section 4.3.3 to clean Pick roller.
	Is there any obstacle in paper path?	Remove obstacles (Refer to section 4.1)
Check lamp is blinking	Blinking 7 times	Follow the procedure described in section 2.2 to release scanner lock.
	Blinking 2, 3, 5, 6, 8 times	First, turn off the scanner and PC. Then power on again to see if Check lamp is still blinking.  If Check lamp is still blinking, contact the manufacturer's authorized service center or the distributor from which you purchased your scanner.

\* "Double feed" means more than 2 papers are fed at the same time.

## A. Installation Specifications

Item		Specifications		
Dimension (mm)		Width	Depth	Height
		445	304	179
Weight (kg)		4.9		
Input power	Voltage	AC100 to 240 V		
	Phases	Single phase		
	Frequency	50 / 60 Hz		
Power consumption	During operation	Less than 24W		
	Stand by	Less than 7 W		
Operating environment	Device status	At Operation	At Stand by	At shipping
	Temperature	15 to 35 C° (59 to 95 F°)	-10 to 60 C° (59 to 95 F°)	-10 to 60 C° (14 to 140 F°)
	Humidity	35 to 80 %	20 to 80 %	20 to 80 %

### Dimensions

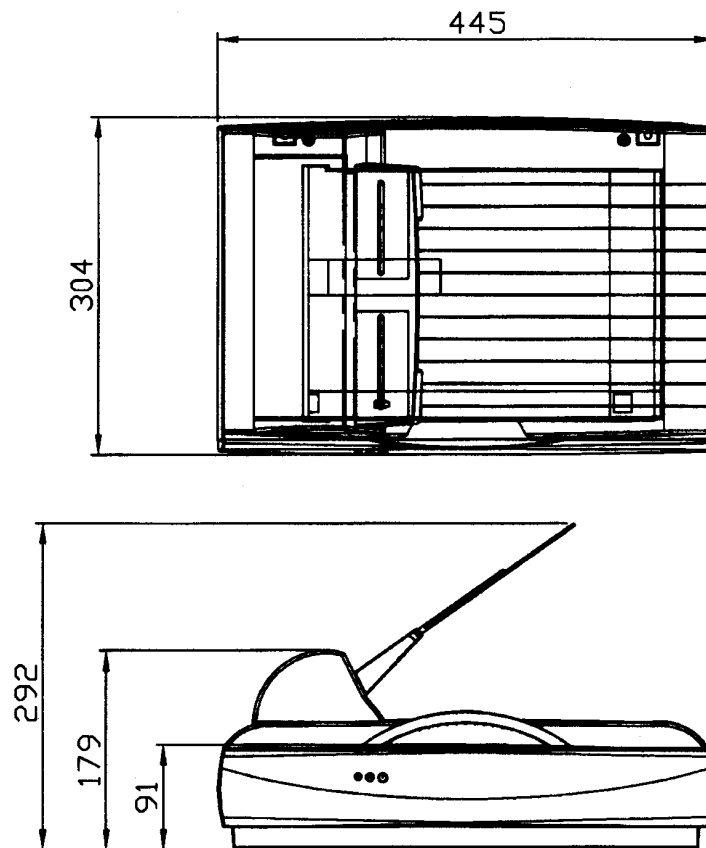

## **GLOSSARY OF TERMS**

### **A4 size**

A standard paper size. Paper size is 210 x 297 mm.

### **A5 size**

A standard paper size. Paper size is 148 x 210 mm.

### **A6 size**

A standard paper size. Paper size is 105 x 148 mm.

### **A7 size**

A standard paper size. Paper size is 74 x 105 mm.

### **A8 size**

A standard paper size. Paper size is 53 x 74 mm.

### **ASCII**

The acronym for American Standard Code for Information Interchange. ASCII is a set of 256 codes (numbered 0 to 255) used to communicate information between a computer and another device such as a scanner.

### **Bit**

The smallest unit of information in computer memory. A bit is a single digit, either a 1 or a 0, in the binary numbering system. Eight bits equal one byte.

### **Double feed**

Detects the accidental feeding of multiple sheets by the ADF.

### **dpi**

Dots per inch.

### **Equipment Error**

An error that cannot be corrected by the operator. Call CE.

### **FB**

In this manual, FB means flat bed.

### **Hexadecimal**

A base-16 numbering system (also commonly referred to as hex numbers). Since a base-16 system requires 16 digits, numbers 0 through 9 and letters A through F are used. It is convenient to express binary numbers in hexadecimal because fewer digits are required.

**Interface**

The connection that allows communication from one part of a system to another. For example, electrical signals are transferred between the computer and scanner over an interface cable.

**Landscape orientation**

A document is transported and read with the long side vertical to the moving direction.

**Letter size**

A standard paper size used in the U.S.A. and other countries. Paper size is 8-1/2 x 11 inches.

**Line drawing mode**

Selecting line drawing mode makes threshold and contrast settings effective but prevents rightness from being set. The specified threshold value determines whether black or white pixels are scanned. Line drawing mode is therefore appropriate for scanning text and line art images.

**Paper JAM**

A warning informing the user that a document is jammed in the transport unit, or that transportation is disabled because the transport unit is slippery.

This warning also appears when a double feed is detected.

**Pick miss**

A mistake to pick up for feed of documents to the ADF.

**Pick start time**

The period from the manual insertion of the document until picking starts after the document passes the hopper empty sensor.

**Portrait orientation**

A document is transported and read with the long side parallel to the moving direction.

**Read operation**

Refers to the reading operation including Simplex reading and Duplex reading.

**RS-232C interface**

A type of serial interface. See Serial interface.

**Serial interface**

A standard computer interface. Information is transferred between devices over a single wire (although other wires are used for control).

With a serial interface, an interface cable greater than 3 meters (10 feet) can be used. This is often necessary in networking environments, where the scanner may be shared.

**Temporary Error**

An error correctable by the operator.

**Time-out limit**

This is the time the scanner waits for the next document insertion after the last document has been fed. The scanner returns Paper Empty when no document is set after time-out limit.



# INDEX

## A

AC Adapter.....	2, 8
ADF.....	11
ADF Cover.....	3, 16
ADF paper chute.....	3
Assemblies.....	3

## C

Cable Connections.....	7
Cleaning.....	18, 19
Components.....	1, 2
Consumables.....	22
Conventions.....	viii
Cover.....	3

## D

Daily maintenance.....	17
Dimensions.....	28
Document bed.....	9
Document cover.....	3, 9
Document stopper.....	3
Document size.....	11
Document type.....	11
Driver installation.....	8

## F

Feeding direction.....	14
Flatbed.....	3
Fujitsu Group Offices.....	iv

## I

Installation specifications.....	28
Interface connectors.....	4, 7

## L

Lamp.....	3
Landscape.....	10

## M

Maintenance.....	16
Mylar sheet.....	19, 21

## O

Operation environment.....	28
----------------------------	----

## P

Pad ASY.....	22
Paper chute.....	3
Paper length.....	12
Paper thickness.....	11
Paper weight.....	11, 12
Pick roller.....	19
Plastic roller.....	20
Portrait.....	10
Power lamp.....	3
Power switch.....	4
Precautions.....	x
Preface.....	vii

## R

Reading face.....	14
Ready lamp.....	3

## S

Scanner driver.....	8
Sensor lever.....	21
Side guide.....	3
Shipping lock.....	5
Specifications.....	28

## T

Troubleshooting.....	26
----------------------	----

## U

Units and Assemblies.....	3
USB.....	7

**W**

Weight.....28

# Declaration of Conformity



## Declaration of Conformity

Responsible Party: FUJITSU COMPUTER PRODUCTS OF AMERICA, INC.  
Address: 2904 ORCHARD PARKWAY,  
SAN JOSE, CA 95134 - 2009, U. S. A.  
Phone Number: (408) 432-6333  
Fax Number: (408) 894-1709

Hereby declares that the product

Product Name: Image Scanner  
fi-4010CU  
Revision: A0 ~

Conforms to the following specifications:

FCC Part 15, Subpart B, Class B Digital Device

Supplementary Information:

This device complies with part 15 of the FCC Rules. Operation is subject to the following two conditions: (1) this device may not cause harmful interference, and (2) this device must accept any interference received, including interference that may cause undesired operation.

### Responsible Person

Name: Reza Majidansari  
Title: V.P. IPG. Engineering  
Peripherals, Scanners and Software  
Signature:   
Date: 4/29/02

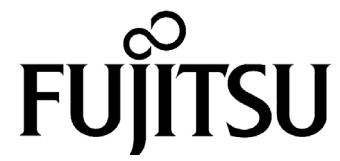

This manual uses recycled paper.